



User's Guide of FASTACE ALX13RC

FASTACE, All rights reserved.

Hello! First of all, thank you for choosing FASTACE, it will always be your trusted partner! In order to let you can ride your motorcycle with safety and fully enjoy the ride pleasure of the FASTACE suspension, please read this manual carefully, and keep it well in case of you will need it one day.

We sincerely hope that you will give us your valuable opinions or suggestions on our design/performance/quality/after-sales service. FASTACE is willing to provide you with more professional products and good service.

This manual includes the following:

1. **Safety Precautions**
2. **Overview**
3. **Features and Essential parameter**
4. **Instruction of air spring and damping adjustment**
5. **Installation & Warning:**
6. **Maintenance**

In order to improve product performance, FASTACE reserves the right to modify the products without prior notice. If there is any difference between the actual product and picture, please take the actual product as the criterion.



FASTACE, All rights reserved.

1. Safety Precautions

1.1-Front fork is one of the most important components of the motorcycle, which directly affects the stability of the motorcycle. Please read this manual carefully and make sure you understand the information before installing and using this product. Any non-standard behavior will result in product work failure, product damage, property loss or personal injury. FASTACE is not responsible for this totally.

1.2-Installation and maintenance of suspension requires professional knowledge, good tools and mechanics' experience. It is strongly recommended that you can let your dealer or FASTACE authorized service center to help you to install and maintenance.

1.3-Do not make any modify on any part of your suspension system.

1.4-Learn to ride not out of your capability. Any riding without control will damage your suspension system directly and affect its service life cycle.

1.5-After installing the product, take a test ride at low speed, to ensure that the suspension installed with stability. It must ride on the safe road and take proper safety measures.

1.6-Always check your suspension if it get deformation, bending, cracking or other damage. If it makes a abnormal sound when riding, the functions are not work or any oil leakage, please stop use it immediately and send the product to FASTACE service center to maintenance.



2. Overview

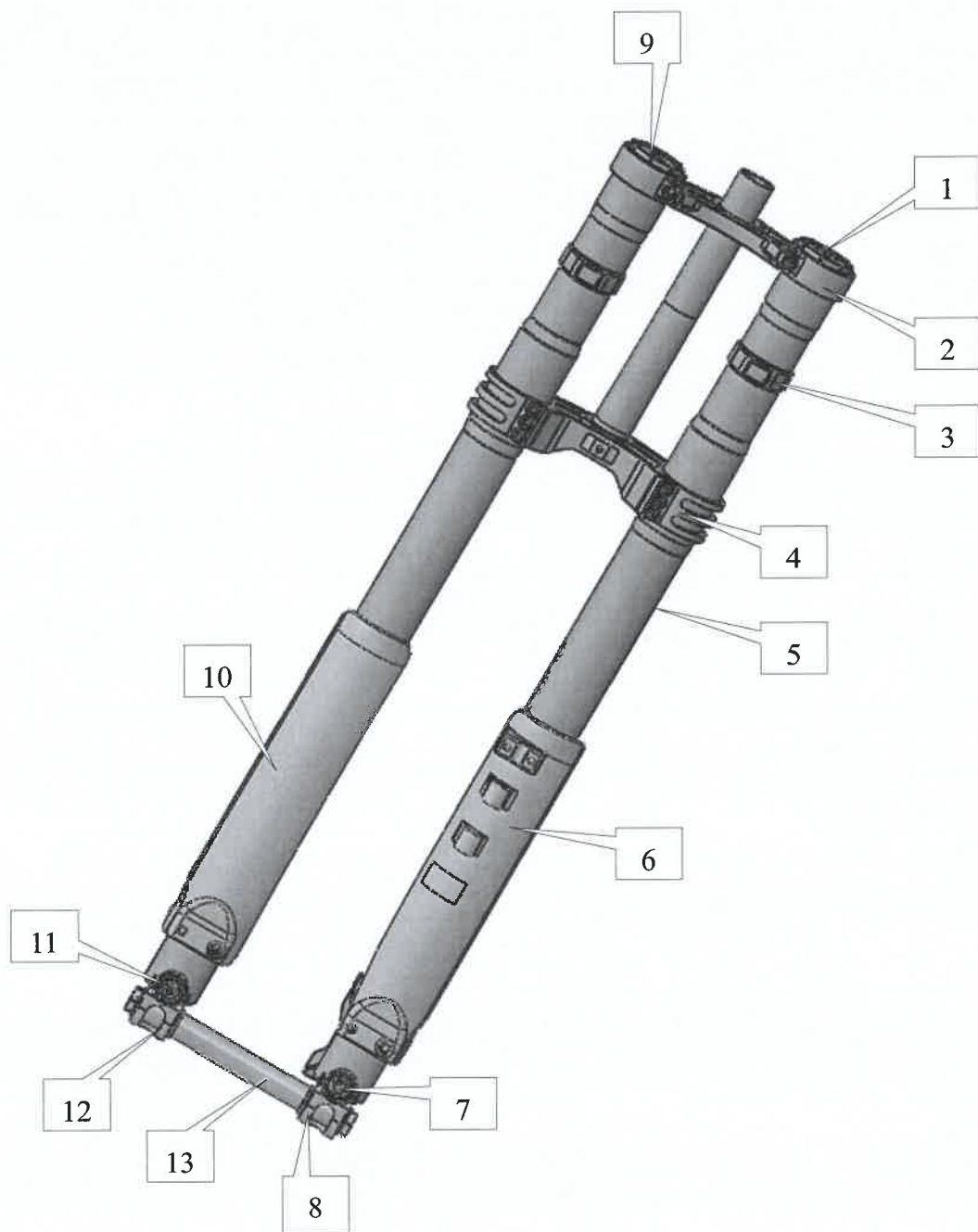

Item :

- 1 : Air valve screw 2 : Upper triple clamp 3 : Direction limit block
4 : Lower triple clamp 5 : Outer tube 6 : Left mudguard
7 : Wheel clamp screw 8 : Left wheel clamp 9 : Rebound adjuster
10 : Right mudguard 11 : Compression adjuster
12 : Right wheel clamp 13 : Front wheel axle

3. Features and Essential parameter

The lighten-pneumatic front fork is specially designed for DH bike by Fastace. The outer tube/stanchion tube/triple clamp/wheel clamps are all made of high-strength and lightweight aluminum alloy, and design steel spring and hydraulic damper inside.

The right tube is a hydraulic damping system, which relies on the damping force produced by the reciprocating motion of piston and valve plate in the hydraulic oil to restrain vibrations and shocks from the road or suddenly acceleration and deceleration. The damper is equipped with high quality oil with abrasion resistance, low condensation point and low oil weight to ensure stable and reliable damping.

The left tube assemble with strong alloy-coil which is reliable and safe.

The front fork contains two functions: Compression adjustment/ Rebound adjustment, so that your bike has more possibility.

Travel: 200mm

Distance: 750mm

4. Instruction damping adjustment

The following external adjustment functions are included:

Rebound damping adjustment

Compression damping adjustment

4.1- Rebound damping adjustment

As shown in Figure 1, adjust the damping with a screwdriver to adjust the axis of the top of the right tube.

Rotating clockwise toward "S" increases rebound damping, it can decrease the speed of front fork extension; rotating counterclockwise toward "F" decreases rebound damping; it can increase the speed of front fork compression.

The rebound adjustment range is 12 clicks. When adjusting, it is usually to adjust to the maximum in clockwise direction and then back to the position request in counterclockwise gently.

Do not screw it too hard, it might make the screw stripped.

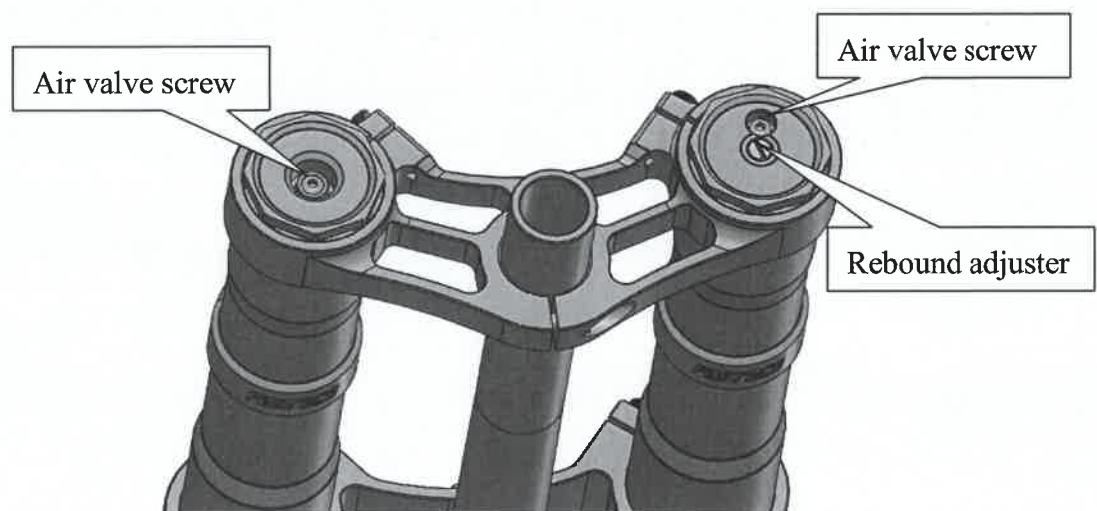

Figure 1

Rebound damping can be set according to riders' weight, habits or road conditions.

When riding on a mountain road or a curved road, turn the rebound adjuster screw clockwise to slow down the rebound, it can reduce shaking; when riding in urban areas or poor roads, the rebound adjuster screw can be turned counterclockwise, so that the rebound will be faster, and it will reduce stiffness and astringency.

After long time riding heavily, the air pressure inside the right tube will increase and cause the front fork to harden. We can use the 3mm hex wrench to loosen the vent screw on the top of the right tube, release the air and screw it tight again.

4.2-Compression damping adjustment

As shown in Figure 2, the compression adjustment axis at the bottom of the fork can be adjusted with a screwdriver to adjust the compression damping during riding.

Turn the screw clockwise can increase the damper when front fork compress, and make rider feel stiffer when riding on ordinary road; turn the screw counterclockwise can decrease the damper when front fork compress, and make rider feel softer when riding on ordinary road.

Adjustment ranges are 12 clicks. When adjusting, turn the screw clockwise to the maximum, and then turn the screw counterclockwise to the required position. Be sure the force should be moderate. Do not screw it too hard, it might make the screw stripped.

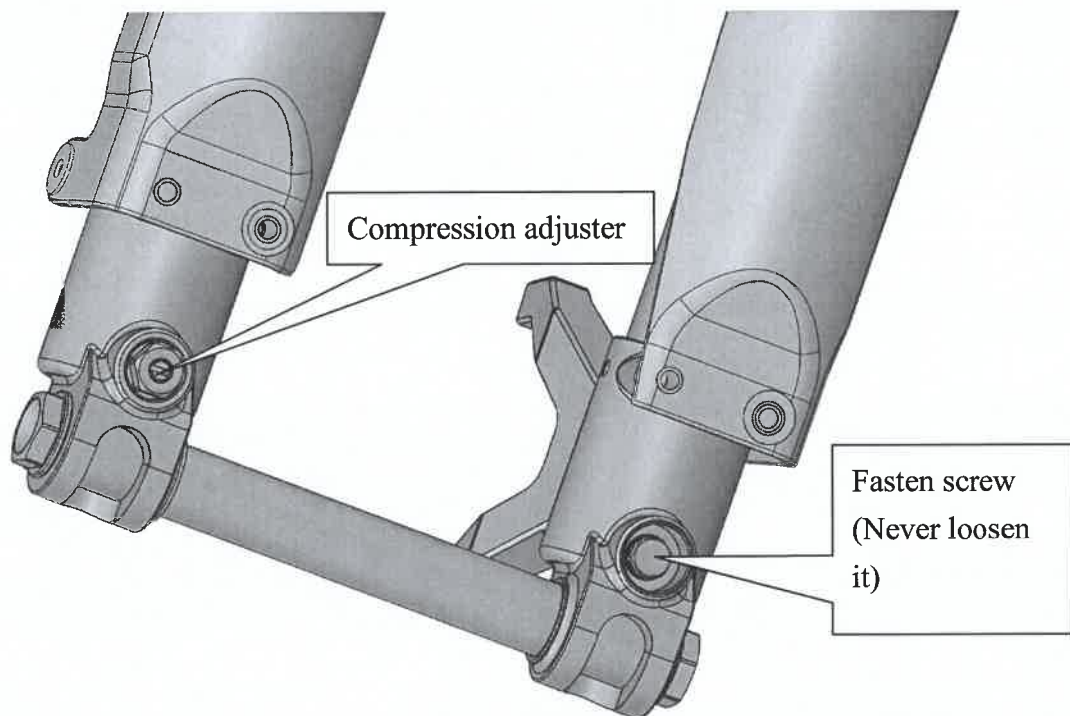

Figure 2

When riding on a flat road, the compression adjuster can be adjusted clockwise in the direction of H to increase damping and it will make riding more stable.

When the weight-load is increased, the compression damping can be increased appropriately to avoid the bottom-hit.

When the motorcycle sinks too fast or when it shakes too much when in the middle of a corner, we can increase some compression damping.

When the motorcycle sinks too slowly or when it become too stiff when riding on a rugged road, the compression adjuster can be adjusted counterclockwise to reduce damping and improve the ride comfort ability.

Warning: Never loosen the screw on left wheel clamp.

Installation & Warning

In order to make the front fork move smoothly, check the width of the hub(A) assembly and the opening width of the front fork before installation, to ensure that the two fork tubes are parallel. The locking torque of the upper and lower plate screw should be within the appropriate range to avoid deformation of the outer tube; it will affect the up and down action of the front fork a lot.

(Recommended screw torque: upper plate is 16-18N.m; lower plate is 10-12N.m)

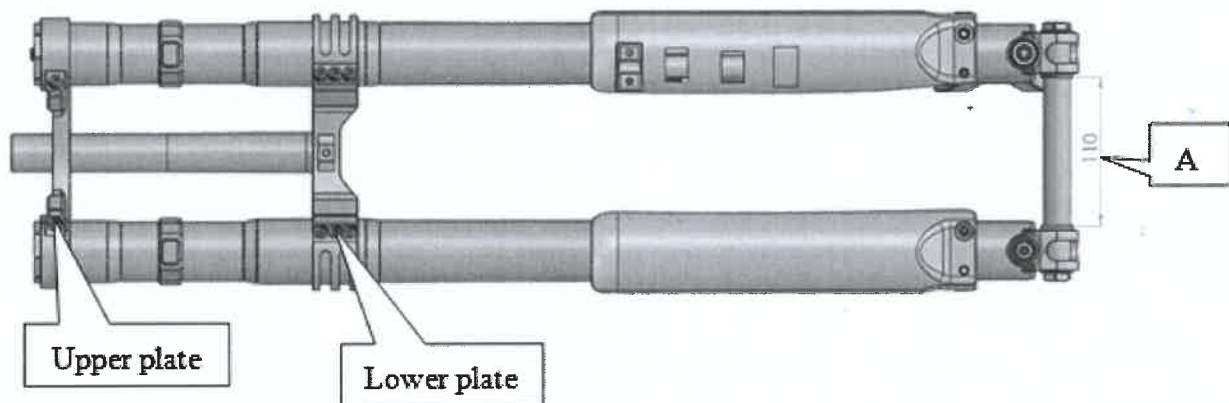

5. Maintenance

The service life cycle of front fork depends on many factors, such as road conditions and driving conditions; any strong impact, high fall, abnormal use or riding too rough can damage the product.

Failure to maintain on schedule or incorrect maintenance will cause damage oil seal, bearing, dust seal, stanchion tube or other components, resulting in oil leakage or slow the respond of front fork.

We suggest a comprehensive maintenance every 10 using-hours.

-Make sure the surface clean:

After every ride, the surface of the front fork must be cleaned immediately, especially the dust or mud on the main pipe.

When cleaning with a high pressure washer, do not flush upward against the dust seal. This will flush the dust into the lip of the oil seal and cause oil leakage.

Do not clean the front fork by flammable or corrosive solution; otherwise it will damage the dust seal. Use neutral soap water or neutral detergent with soft cotton rag.

After cleaning, the surface of stanchion tube should be coated with a thin lubricating grease and press the front fork several times, so that the front fork is fully lubricated.

6. Warranty:

6.1-General rule:

6.1.1-Definition: The quality problems caused by materials or workmanship during the warranty period, as is confirmed by FASTACE, FASTACE will provide either repair or change the defected components.

6.1.2-Warranty period: 6 months from the date that suspension sold.

6.1.3-Principle: the warranty is mainly based on repairing the suspension.

6.2- Requirements of warranty:

The suspension manufactured by FASTACE is guaranteed to be of quality assurance. Any suspension purchased by our company will be repaired or replaced free of charge within 6 months from the date of purchased if it is found that any terrible influence of material or workmanship affects the user. In one of the following cases, warranty service will be VOID.

If the product out of warranty, FASTACE will still help the users to maintenance their suspension, but the users will need to pay for the spare parts and labors appropriately.

-VOID:

6.2.1-Out the warranty period (depend on the date of valid invoice).

6.2.2-Traffic accidents or apply on improper use, such as acrobatics, trial-riding, high-fall, etc., that abnormal damage cause from human.

6.2.3-Not follow the manual to use/maintenance/operate the product.

6.2.4-Natural aging and normal wear (e.g. oil, oil seal, dust seal, bearing and natural fading of the surface of parts).

6.2.5-Users should take full responsibilities if they repair or modify the suspension themselves, including use of parts not from FASTACE.

6.2.6-Damage caused by natural, disaster or any irresistible force

6.2.7-Cannot provide warranty card and valid invoice from FASTACE or altered or erased factory number without authorization.

Furthermore, FASTACE does not bear the freight of transportation, delayed work fee, and compensation for inconvenience or inability to use during maintenance.

If you have any questions, please consult your distributor or FASTACE after-sales service department.

Always consult and refer to your vehicle service manual when using our product.

FASTACE has the final interpretation of the instructions, subject to change without notice.

FASTACE PRECISION METALS (ZHONG SHAN) CO;LTD

Guang Dong, China

cn168@fastace.com

www.fastace.com

FASTACE, All rights reserved